

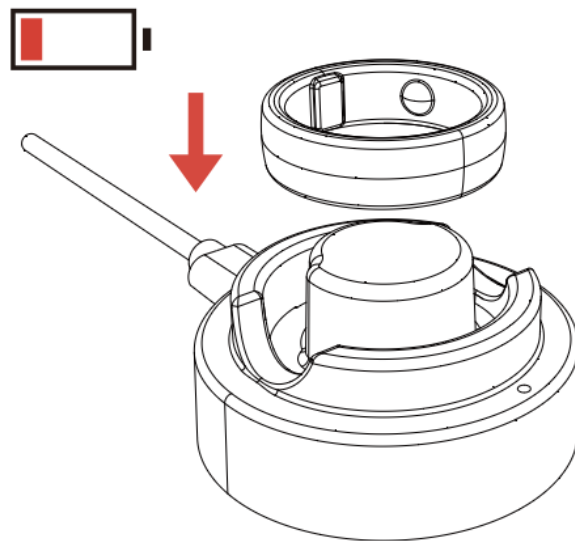

Quick Start Guide

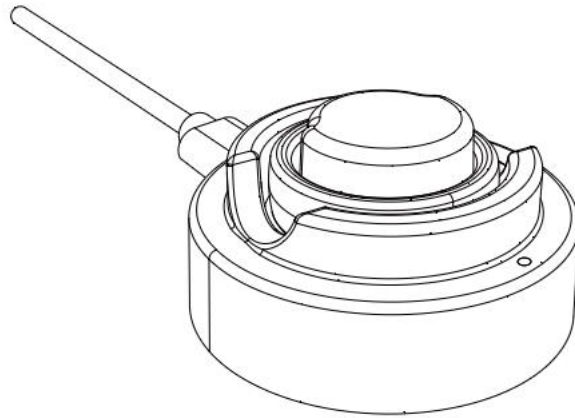

Your Inspiring[®] has low battery.



Connect your Inspiring[®] to the charging dock & charge it for at least 2 hours the first time.

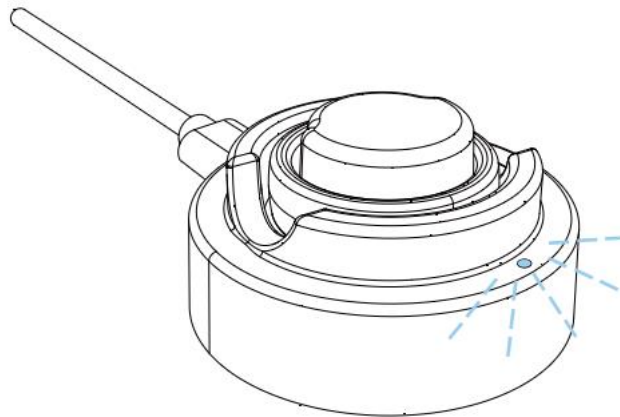

Slowly pulsing white light indicates your Inspiring[®] is charging.

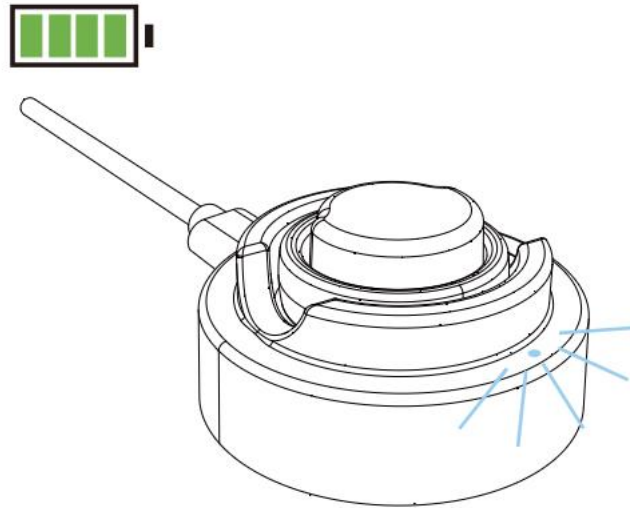

Solid white light indicates your Inspiring[®] is fully charged.



Download the Inspiring[®] App.



Search on Google Play or the App Store and install the App.

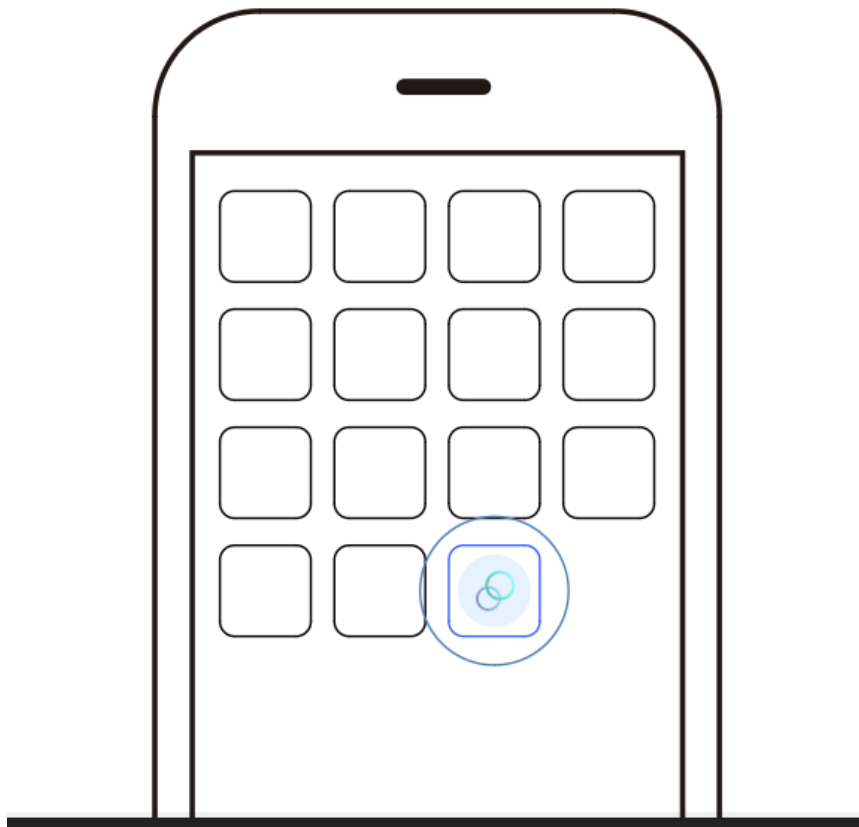

Open Inspiring® App and create your own Inspiring® Account.



Please connect your Inspiring® to the charging dock and follow the instructions on the app.

Upgrade from version 0.0.7

Everyone upgrading from version 0.0.7 must follow these steps for connection. This is a one-time occurrence for those updating from 0.0.7 for the first time.

1. **First, Update the Firmware:** Upgrade the firmware from 0.0.7 in the Inspiring app.
2. **Go to Factory Settings on the Ring:**
 - a. Go to **You > Settings (top right) > Smart Ring > Factory Reset > Confirm.**
3. **Next Step:**
 - a. Go to **You > Settings (top right) > Smart Ring > Heart Rate Measurement Accuracy.**
 - b. Select between **Standard, Medium, and Optimal**, and wait for 5 minutes; then the ring will be ready for use.
 - c. Make sure it says **"Setting Success"** when you select the mode.

Upgrading from version 0.0.7

Anyone upgrading from version 0.0.7 must follow these steps in order to connect. This is a one-time requirement for those updating from 0.0.7 for the first time."

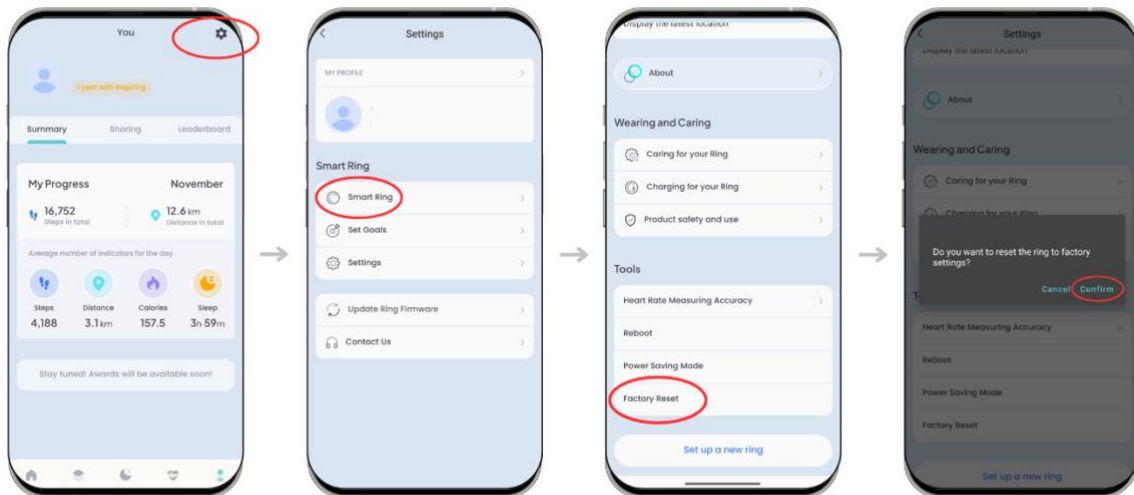

1. Upgrade the firmware from 0.0.7 in the Inspiring app.
2. Go to factory settings on the ring: Go to You > Settings (top right) > Smart ring > Factory reset > Confirm.

After upgrading from 0.0.7 and factory reset.

Everyone upgrading from version 0.0.7 must follow these steps for connection. This is a one-time occurrence for those updating from 0.0.7 for the first time.

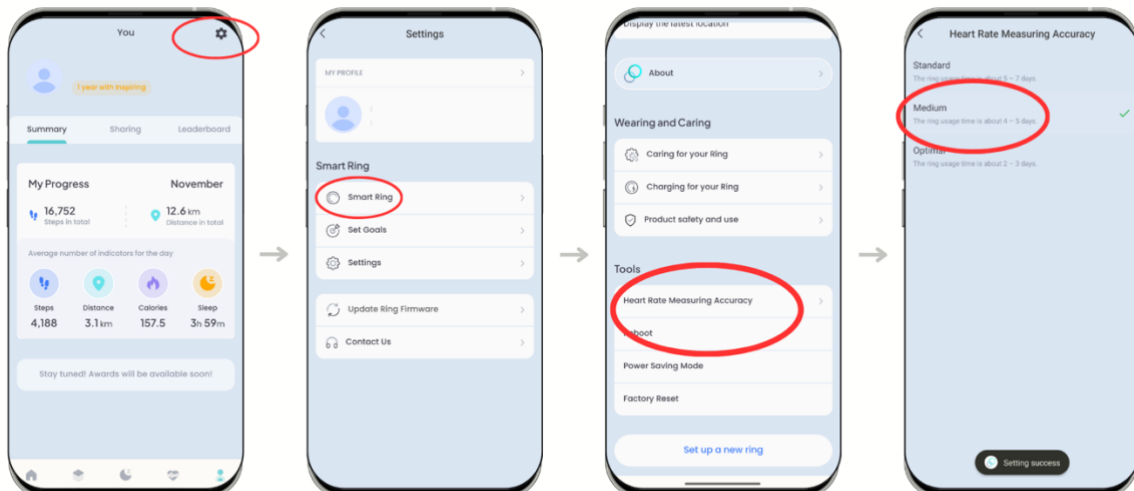

1. Go to You > Settings (top right) > Smart Ring > Heart Rate Measurement Accuracy.
2. Select between Standard, Medium, and Optimal, and wait for 5 minutes; then the ring will be ready for use.
3. Make sure it says 'Setting Success' when you select the mode.

Inspiring® Smart Ring – Complete User Manual

Welcome to Your Inspiring® – Your Gateway to Smarter Health

Thank you for choosing Inspiring® Smart Ring, the advanced wearable technology designed to help you lead a healthier, more balanced lifestyle. Our mission is to give you real-time insights into your body's needs and empower you with the information you need to make better decisions for your overall well-being.

Please take the time to carefully read through this manual before using your smart ring, the Inspiring® app, and related services. By doing so, you can ensure safe and proper use, as well as maximize the full potential of Inspiring®'s advanced features.

Support and Assistance

For setup help, troubleshooting, or questions about your ring or the app, refer to the **Quick Start Guide, FAQ, and Troubleshooting** sections on www.inspiring.no. You can also use Maya, our intelligent AI assistant, directly within the Inspiring® app. Maya provides real-time guidance, navigates app features, and delivers personalized health insights. If Maya cannot resolve your issue, you'll have the option to create a support ticket by filling out a form, and our customer support team will contact you directly.

For further support, contact us at support@inspiring.com.

Transform your health journey with Inspiring®

Harness the power of Norwegian technology through AI, real-time tracking, and a vibrant community—all without subscription fees.

Safety Instructions

Using the Inspiring® smart ring safely is important for ensuring a positive experience. Please take the following precautions:

Medical Disclaimer

The Inspiring® Smart Ring and its related services are **not intended** to diagnose, treat, cure, or prevent any medical condition. The data provided by the ring should be used for informational purposes only and **must not replace medical advice** from qualified healthcare professionals.

Always consult a doctor if you are considering significant lifestyle changes or need medical advice regarding the data from the ring.

Listening to Your Body

It's important to recognize that everybody is unique. While the Inspiring® ring provides valuable insights, some individuals may experience data deviations due to:

- **Physiological differences:** Certain medical conditions or genetic factors can cause variations.
- **Unusual reactions:** Prolonged or repeated fatigue, discomfort, or pain after using the ring may indicate an underlying issue that should be addressed by a healthcare provider.

If you experience **persistent pain** or **discomfort** while using the ring or after changing your activity patterns, consult a healthcare professional immediately.

Skin Irritation

The Inspiring® ring is made from **non-allergenic materials**, but in rare cases, users may experience skin irritation. To avoid this:

- **Remove the ring immediately** if you notice any redness or irritation.
- If the irritation persists for more than **2-3 days**, consult a dermatologist.

Safe Usage

Ensure that the ring is not caught in any objects during physical activities such as lifting heavy items. In emergencies where the ring cannot be removed, use cold water and soap to help ease it off or, as a last resort, cut the ring from the thinnest point.

Use, Care, and Maintenance

To keep your Inspiring® ring in optimal condition, follow these usage and care guidelines:

Wearing Your Inspiring®

It is recommended to be worn on the index, middle, or ring finger of the left hand, or on the hand you use the least.

Charging Your Inspiring®

Charging your Inspiring® ring is quick and convenient, taking anywhere from **30 to 90 minutes** depending on the battery level. It's recommended that you fully charge your ring for the first time. You can easily monitor your ring's battery status by checking the **upper right-hand corner** of the Home tab in the Inspiring® app.

To charge your ring:

1. Place your ring on the **wireless NFC charging dock**, ensuring that the ring is properly aligned with the dock for optimal charging.
2. The charging dock will display different **white light indicators** to show the charging status:
 - A **slowly pulsing white light** indicates that your Inspiring® is charging.
 - A **solid white light** indicates that your Inspiring® is fully charged.
3. Once the white light turns solid, the charging process is complete, and you will receive a **push notification** from the Inspiring® app confirming that your ring is fully charged.

If the white light does not turn on:

- Ensure the ring is placed correctly on the **NFC charging dock** and that it is properly connected to a power source.
- Try disconnecting the charging dock from the power source, wait a few moments, and reconnect it.

Removing the Ring

Finger size can fluctuate depending on **time of day, temperature, and activity levels**. If the ring becomes difficult to remove:

1. Wet your finger with **cold water and mild soap**.
2. Gently twist the ring while raising your hand above heart level to reduce swelling.
3. In extreme cases, use a ring cutter to remove the ring from the thinnest point.

Cleaning the Ring

Keep your ring clean by:

- Wash it regularly with **mild soap** and water.
- Wipe it down with a soft cloth to avoid scratches.
- Do not expose the ring to **harsh chemicals** or **abrasive cleaners**.

Water and Impact Resistance

The Inspiring® Smart Ring is **waterproof** up to **100 meters (328 feet)**, making it suitable for swimming, showering, and other water activities. However, avoid wearing the ring during extreme temperatures beyond the range **-20°C and 60°C (-4°F and 140°F)** such as in the sauna or ice baths. **High-impact activities like weightlifting, shoveling, or using heavy tools, this can cause scratches on the outer shell.**

Also, avoid wearing Inspiring® alongside other rings made of **metal, ceramic, or precious stones like diamonds**, as this can cause scratches on both the ring and the other jewelry.

Technical Specifications

Here is a more detailed breakdown of the technical aspects of your Inspiring® Smart Ring:

Materials

- **Outer surface:** Titanium with **PVD coating** in Silver, Gold, Dark Grey, and Rose Gold.
- **Interior surface:** Non-allergenic, non-metallic seamless molding.

Battery

- **Capacity:** 15-22 mAh (dependent on ring size).
- **Battery life:** Up to 5-7 days (depending on usage and activity).
- **Charging time:** 30-90 minutes using the Inspiring® charging dock.
- **Connection:** Bluetooth Low Energy (Bluetooth Smart®).

App Compatibility

- Available on both **iOS** and **Android** platforms through the **App Store** and **Google Play Store**.
- **Secure data encryption** ensures a safe connection between the ring and the Inspiring® app.

Environmental Tolerance

- **Waterproof** up to **100 meters (328 feet)**.
- **Drop resistance:** Withstands drops from **1 meter (3.3 feet)**.
- **Operating temperature:** Efficient performance between **-20°C and 60°C (-4°F and 140°F)**.

Memory and Updates

- **Memory capacity:** Stores up to **7 days** of data, which can be synced to the Inspiring® app.
- **Software updates:** Available through the app for improved performance and new features.
- **Firmware upgrades:** Available through the app for improved performance

Weight & Dimensions

- **Width:** 7.9mm.
- **Thickness:** 2.8mm
- **Sizes:** 6, 7, 8, 9, 10, 11, 12, 13
- **Weight:** 5-7 grams depending on size
- **Color:** Lunar Silver, Eclipse Grey, Solara Gold, Rosium Gold
- **Package Includes**
 - 1 x Inspiring® Smart Ring
 - 1 x USB Power Cable
 - 1 x Wireless Charging Dock
 - 1 x Electronic User Manual

Warranty and Liability

Supplier Warranty

Inspiring® provides a two-year limited supplier warranty covering material and manufacturing defects. This warranty does not cover:

- Normal wear and tear, such as scratches or dents.
- Damage caused by misuse, accidents, inadequate maintenance, or unauthorized repairs.
- Consumable components like batteries, unless the damage is due to material or manufacturing defects.

If a defect occurs within the warranty period, Euron Connect AS will repair, replace, or provide a refund at its discretion. Repairs or replacements performed under warranty come with an additional 90-day warranty for those components.

Consumer Rights under the Norwegian Consumer Purchase Act

In Norway, consumers have a statutory right to claim under the Consumer Purchase Act for up to five years for products expected to last significantly longer than two years, including electronics with non-replaceable batteries like the Inspiring® Smart Ring. This right runs alongside the supplier warranty, covering defects or issues not caused by normal wear or misuse.

If a defect appears after the supplier warranty has expired but within the five-year period, you are still entitled to claim, provided the fault is not a result of expected wear and tear from regular use.

Limitation of Liability

Euron Connect AS, along with its affiliates, is not liable for direct or indirect damages resulting from the use of Inspiring® products and services, including loss of data or business disruptions.

In some regions, legal limitations may not permit certain liabilities to be waived, so the full scope of liability will align with local laws.

Disposal Instructions

Join the green future – recycle your Inspiring® ring and get 199 NOK back or trade it in for a new ring and receive a 790 NOK discount for a more sustainable world! Or in compliance with the **2012/19/EU Directive**, electronic devices must be disposed of responsibly. Please recycle your Inspiring® ring and its components through designated electronic waste programs in your area. Do not mix with household waste.

For full terms of service, privacy policies, and additional regulatory information, visit our website: www.inspiring.no

